

CASE II
AGRICULTURE

AXIAL-FLOW[®]

50 SERIES COMBINES



INTRODUCING THE AXIAL-FLOW 250 SERIES COMBINES.

With 250 series Axial-Flow combines, you get the latest advancements, without sacrifice. Case IH offers the industry's largest lineup of combines to meet the needs of any operation. From header to spreader, Axial-Flow series combines are designed to be reliable and preserve the quality of more than 134 grain types, so you can simply harvest more of what you grow. Now that's high-efficiency harvesting.

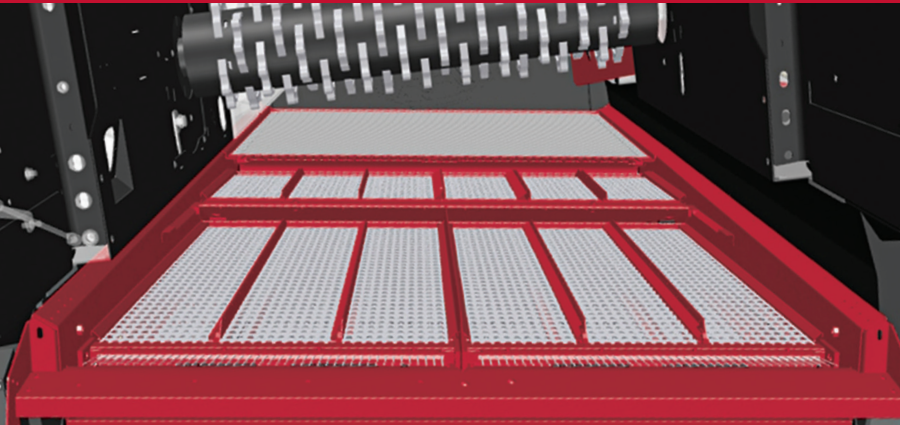

Adjustable cage vanes in base specification.
In-cab adjustable cage vanes optional.

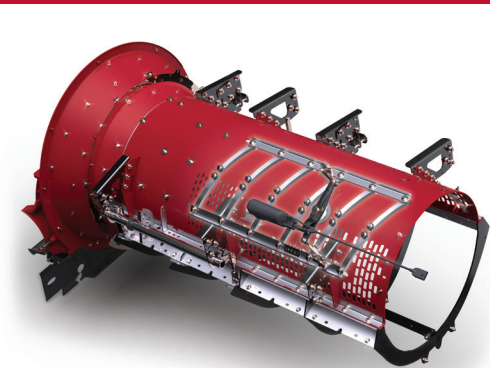

Adjustable cage vanes provide the operator the ability to optimise threshing and separating.

SELF-LEVELLING CLEANING SYSTEM.

The self-levelling cleaning system (SLS), standard on Axial-Flow 250 series combines, saves grain and increases productivity on flat ground as well as on hills. The entire system (grain pan, top sieve, bottom sieve and fan) levels itself for optimum cleaning efficiency on flat fields or hills and banks on end row turns, minimising potential grain loss.

Axial-Flow combines lead the industry in cleaning area. In each class size, the Axial-Flow cleaning area is larger, delivering cleaner samples with minimal losses and matched capacity.

The 250 series now includes an in-cab adjustable pre-sieve that allows the operator to make adjustments on the go, which help maximise grain quality.

■ **Active grain pan.** Designed for high capacity, an active grain pan is utilised on the Axial-Flow 250 series combines. The active grain pan helps stratify material, leaving the heavy seeds at the bottom of the pan and the lighter MOG (material other than grain) at the top. When the layers move onto the sieves, the grain falls and the MOG is lifted in the air by the Cross-Flow cleaning fan.

ADVANCING SINGLE-ROTOR DESIGN.

The AFX rotor features constant pitch impellers that draw the crop and air into the rotor. The AFX rotor can be set in many configurations, adapting to both crop and threshing conditions with the use of straight bars, spiked rasp bars and helical kickers. Competitive rotor and cage designs can reduce productivity and increase grain damage because of inefficient feeding and crop-control designs.

- **Transition cone.** The transition cone is a patented feature of Axial-Flow series combines. Its simple geometry transitions crop from feeder to rotor. Crop smoothly accelerates in a spiral motion from 8 kph to about 95 kph.
- **Concave/module wrap.** Concave/module wrap is one of the most important elements affecting combine capacity. While other brands use longer rotors, Case IH uses the concave/module wrap to gain capacity. All Case IH combines use a 30-inch diameter rotor. The Axial-Flow 150 series uses 156 degrees of concave wrap while the 250 series utilises 180 degrees of module wrap.
- **New adjustable cage vanes.** Available on the 250 series, optional in-cab adjustable cage vanes adapt the threshing system to changing loads and crop conditions. This helps maximise throughput and optimise grain savings. The standard feature includes a gang of cage vanes that are manually adjustable with an easy turnbuckle handle.

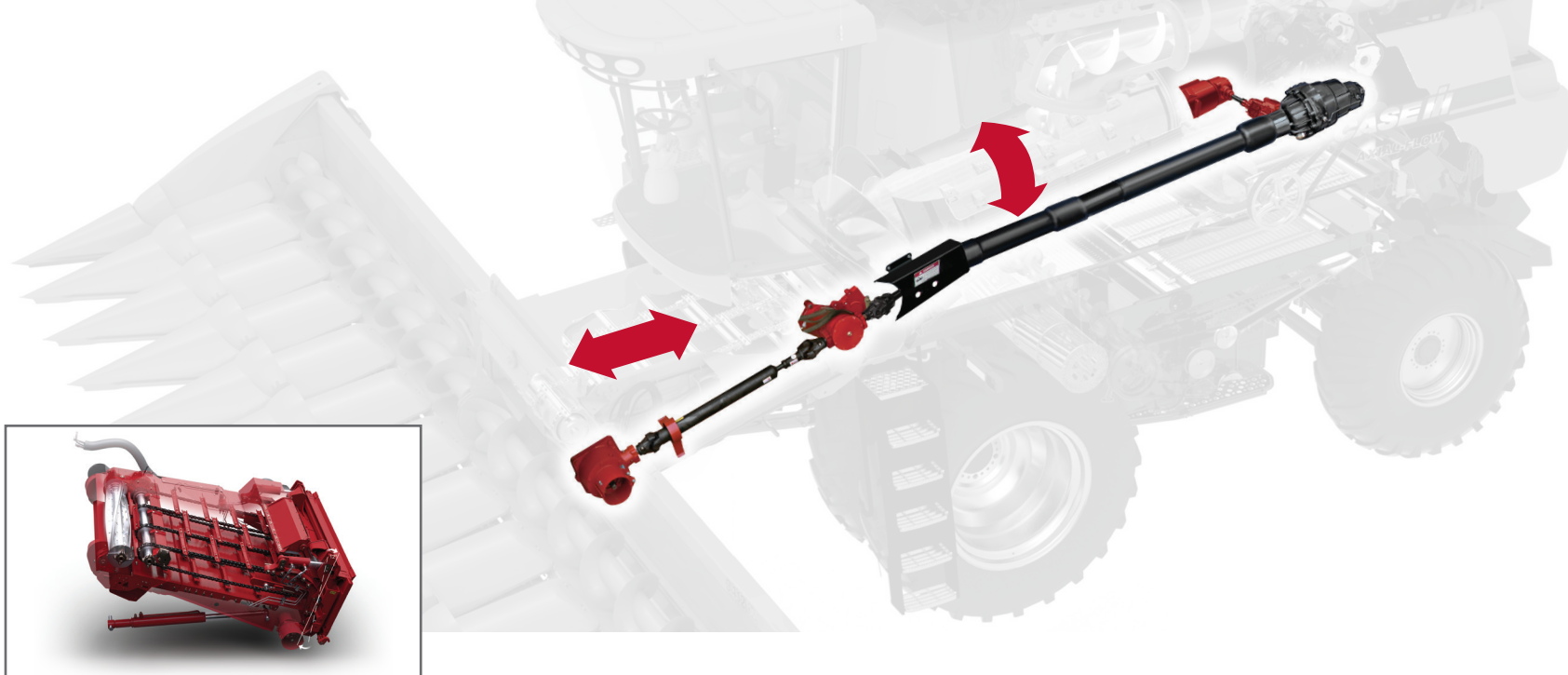

REDESIGNED FEEDER HOUSE.

High-capacity features and heavy-duty feeding systems help ensure a smooth harvest. The 250 series combines have had significant upgrades to improve feeding as well as capacity. The feeder structure has been strengthened and the floor geometry revised on certain variants to improve durability and crop flow. To complement these enhancements, a new feeder pivot pin, larger feeder chains and enhanced header height control software have also been added to improve the package. The 250 series combines also include optional advancements to the feeder house such as heavy-duty feeder lift cylinders, designed to handle up to 18 row narrow chopping corn heads.

Other new features include:

- Optional feeder face fore/aft control allows you to make adjustments from the cab.
- Redesigned feeder top shaft drive coupler features a crowned spline design for greatly improved durability and reliability.
- A simple two-piece feeder floor design increases durability and improves crop feeding.

2-SPEED ELECTRIC SHIFT GROUND DRIVE.

This new transmission simplifies operation so you can use first gear for harvest and second gear for roading. Additional features include:

- Delivers wider speed ranges with more power for climbing hills and propulsion through challenging ground conditions.
- Reduces the need to stop and shift in field or on road.
- Uses a high/low switch on the console to toggle between low and high ranges during harvest. This provides additional operator control when extra traction or a change in speed is required.
- Uses closed-loop sensing for constant speed control (like cruise control in a car).
- Provides greater torque through a wider speed range without shifting due to increased displacement of pumps and motors.
- Improves traction and field performance with optional differential lock that is electrically actuated and hydraulically engaged.
- Provides enhanced road mode features to:
 - Improve fuel savings during transport
 - Maximise fuel savings with economy mode and auto-idle RPM to automatically adjust engine RPM

PATENTED, REVOLUTIONARY POWER PLUS CVT DRIVES.

Our innovative Power Plus™ continuously variable transmission (CVT), pioneered and patented for more than 10 years, features a belt-free, low-maintenance design with variable speed drives and unique in-field capabilities, including rotor de-slug and our patented corn head to groundspeed syncing that helps save time, boost productivity and deliver the ultimate in operator control.

CVT drives are specifically built to accommodate the higher horsepower demands of our 7250, 8250 and 9250 series combines. It's an exclusive technological advancement you won't find on any other manufacturer's machines. The three-speed rotor gearbox optimises the speed range for peak efficiency. With a CVT drive, you get the convenience of hydraulic variable control and the efficient power transfer of a mechanical system. Plus, unique in-field capabilities like patented header to groundspeed syncing for corn heads, ensures smooth material flow from header to spreader.



8250

AF

CASE IH

AXIAL-FLOW

CASE IH

AXIAL-FLOW

INTRODUCING AFS HARVEST COMMAND™ — WELCOME TO HIGH-EFFICIENCY HARVESTING.

Significant advancements in combine automation, and available only on the 250 series Axial-Flow combines, lead the way in the future of harvesting technology. AFS Harvest Command™ automation proactively adjusts the combine as crop conditions change using exclusive, patent-pending technology. You choose the level of automation from four modes of performance. From there, AFS Harvest Command™ automation, with its 16 sensors throughout the machine take over controlling seven combine adjustments. This technology helps the inexperienced operator achieve the productivity of an expert operator.



CHOOSE FROM FOUR MODES OF AUTOMATION TO FIT YOUR OPERATION.

- **Performance:** Maximise grain savings and grain quality while optimising throughput.
- **Grain Quality:** Maximise grain quality while also saving grain and optimising throughput.
- **Max throughput:** The operator can maximise throughput while automation adjusts combine settings to save grain.
- **Fixed throughput:** The operator can fix the machine throughput and the machine will adjust to save grain and maintain a quality sample.

MAKE EVERY DRIVER AN EXPERT OPERATOR.

Fine-tuning harvest settings and adjustments can test even the most experienced operator. AFS Harvest Command™ automation helps refine the harvesting process by reducing the number of functions you need to monitor in the cab from 12 to three. With AFS Harvest Command™, you control concave clearance, header position, and grain tank unload while the automation system takes care of the rest for you.

BOOST PRODUCTIVITY WITH OPTIMAL SETTINGS.

For expert operators, AFS Harvest Command™ allows you to be more relaxed as conditions change and improve output and grain quality.

FIRST CUSTOMER REACTIONS.

“Labour is important. Whether you’ve run a combine for 50 years or 50 minutes, this machine is super user-friendly. The fact you can grab someone off the street and get the same results as someone that has run one forever is extremely appealing to us.”

— **Mark Bartlett**

Colby, Kansas

Running an Axial-Flow 8250 combine with 3162 draper head.

FIND YOUR PERFECT FLOW WITH AFS HARVEST COMMAND™.

Regardless of the time of day, crop conditions or moisture levels, AFS Harvest Command™ is always working for you. It's simple, just choose the mode of automation to match your harvesting goals. From there, AFS Harvest Command™ takes over. Each automation mode prioritises different harvesting outcomes — from grain quality, to grain savings, to throughput — and continually optimises machine performance based on the limits set by the operator.

PERFORMANCE MODE.

- Automation to achieve maximum grain savings and grain quality while optimising throughput.
- **Situation:** The harvest season is progressing well. Conditions are nearly ideal, with no weather threats looming. Your aim is to hit the sweet spot that optimises grain savings, grain quality and throughput.



GRAIN QUALITY MODE.

- Automation to achieve maximum grain quality in the tank, while also saving grain and optimising throughput.
- **Situation:** Your goal is to deliver the highest-quality grain possible, perhaps to earn premiums for food-grade grains or seed crops. You want minimal cracked and broken kernels, while providing a clean grain sample.





MAX THROUGHPUT MODE.

- The operator can maximise the throughput and the machine will adjust to save grain and maintain a quality sample.
- **Situation:** Harvest is at a critical juncture. The forecast is a concern. It's time to wrap up harvest. You need to maximise the acres you harvest each day without sacrificing grain loss or quality.



FIXED THROUGHPUT MODE.

- The operator can fix the machine throughput and the machine will adjust to save grain and maintain a quality sample.
- **Situation:** Steady progress wins the harvest. Your workforce includes less-experienced combine operators. Rather than asking those operators to fine-tune settings and operation — potentially leading to unacceptable grain loss or damage — set a consistent, steady pace and maximise your quality of work.

150 SERIES — A LOOK TO THE FUTURE; A NOD TO THE PAST.

Axial-Flow 150 series combines feature the legendary single-rotor technology, combined with the Cross Flow™ cleaning system and increased grain-handling capacity, to put more high-quality grain in the tank. Now, you can bring a piece of the IH legacy to your farm with this special-edition heritage combine. These heritage models are a salute to the original Axial-Flow combine that revolutionised the combine industry when launched. In addition, the 150 series recognises the advancements made to the combine productivity, such as the Cross Flow cleaning system, the two-speed electric shift transmission, the increased grain-handling capacity, and the hydraulically driven residue package. Also new for 2019 is the option of a differential lock on the 2-speed transmission.



CELEBRATE THE LEGACY OF AXIAL-FLOW COMBINES.

To commemorate the legacy of Axial-Flow combines, all Model Year 2019 150 series combines come with a special edition heritage paint scheme. Reminiscent of the original 1977 combine, the retro paint job features the IH grain tank decal, side panel model decals, and a white roof and rims.

ALL THE FEATURES YOU TRUST AND RELY ON.

■ Cross Flow Cleaning System:

- Increases productivity up to 20 percent.
- Largest cleaning system in the industry for Class V to VII combines.
- Auger bed with six extended-wear augers.
- Patented Cross-Flow fan (450 to 1,300 rpm fan range).
- Cross Flow cleaning system compensates for hillsides; designed to maximise cleaning capacity up to 12 degrees.
- Provides increased capacity even on level ground.

■ 2-speed electric shift transmission:

- Provides 1st gear for harvesting and 2nd gear for roading.
- Hi-low propulsion system provides the ability to shift from low to high range in the field and on the go.
- Provides increased propulsion and improved tractive effort for adverse field conditions and to pull out of fields and onto roads easier.

■ Residue management system:

- A two speed 28 fixed blade straw chopper is standard fitment.
- Standard dual hydraulic disc spreaders with fold out feature.

■ High-capacity harvesting:

- Clean grain elevator handles up to 5,000 bu. per hour.

■ AFX rotor:

- Creates smooth crop flow.
- Improves throughput.
- Puts more high-quality grain in your tank.
- 156 degrees of concave wrap.
- Split concaves weigh 17 kilograms each.
- Adjustable cage vanes improve threshing and throughput.



CASE IH 7150

AXIAL-FLOW COMBINE

CASE IH

150 SERIES SPECIFICATIONS	AXIAL-FLOW 7150
Combine Class Size	Class VII
ENGINE	
Displacement	8.7 L
Horsepower (Rated / Maximum)	375 hp (280 kW) / 442 hp (330 kW)
Power Rise	67 hp (50 kW)
Fuel Tank	945 L
FEEDER	
Feeder Width	45.5 in. (1 156 mm)
Feeder Length w/o Rock Trap	45 in. (1 143 mm)
Feeder Drive Type	Belt
Reverser System	Hydraulic
Head Lift Cylinders Standard	3.35 in. (85 mm)
Lateral Tilt Range	+/- 5 degrees for a total range of 10 degrees
Stone Trap (Factory Order Option Only)	Beater/Sump
THRESHING/SEPARATING	
Threshing Type	Rotary
Rotor Drive Type/Rotor Diameter	Belt Drive/30 in. (762 mm)
Rotor Speeds	250–1150 rpm
# of Concave	6
Threshing/Separating Area Wrap	156.5°/133°
Separating Grates	3
Residue Control	Straw Chopper, 28 fixed knives, 2-speed with dual hydraulic drive disc spreaders
Auger Bed	Yes
Active Grain Pan	No
Grain Loss Monitor	Standard Equipment
CLEANING SYSTEM	
Cleaning System Width	56 in. (1 422 mm) CrossFlow Cleaning System
Total Sieve Area	8,370 sq. in. (5.40 m ²) CrossFlow Cleaning System
Fixed or Self-Levelling Cleaning System	CrossFlow
Cleaning Capability % Slope (Degrees)	12° CrossFlow
Sieve Louver Adjustment (In-Cab/Manual)	Standard/N/A
Cleaning Fan Type/Drive	CrossFlow/Belt Variator
Fan Speed Range	450–1,300 rpm
Fan Diameter	290 mm
CONVEYING AND STORAGE	
Tailings Elevator	Tailings return to rotor
Clean Grain Elevator (Dimensions/Capacity)	9 × 15.9 in. (229 × 404 mm) / 5,000 bu/hr.
Grain Tank Capacity	300 bu. (10 560 L)
Unloading Auger Length	25.8 ft. (7.86 m)
Unloading Rate	3.2 bu. (113 L) per second
DIMENSIONS	
Wheel Base	3 815 mm
Width (Overall Single Tires 120-in. Tread)	3 833 mm
Minimum Weight (2WD and Single Drive Tires)	15 808 kg
Typical Weight (2WD and Dual Drive Tires)	17 168 kg
Cab Height	3 907 mm

250 SERIES SPECIFICATIONS	AXIAL-FLOW 7250	AXIAL-FLOW 8250	AXIAL-FLOW 9250
Combine Class Size	Class VII	Class VIII	Class IX
ENGINE			
Type - Tier II	Case IH - FPT		
Displacement	11.1 L	12.9 L	16.0 L
Horsepower (Rated/Maximum)	403 hp (300 kW)/468 hp (349 kW)	480 hp (358 kW)/555 hp (414 kW)	550 hp (410 kW)/625 hp (466 kW)
Power Rise	66 hp (49 kW)	75 hp (56 kW)	
Fuel Tank	1 125 L		1 200 L
FEEDER			
Feeder Width	54 in. (1 372 mm)		
Feeder Length w/o Rock Trap	94 in. (2 388 mm)		
Feeder Drive Type	Fixed Speed (CVT drive optional)		
Reverser System	CVT hydraulic		
Head Lift Cylinders	90 mm/95 mm (Factory Order Only)		
Lateral Tilt Range Optional	+/- 5 degrees for a total range of 10 degrees		
Fore/Aft Faceplate Tilt/Optional	12 degrees/in-cab adjustable		
Stone Trap (Opt)	Spiral Beater/Sump		
THRESHING/SEPARATING			
Threshing Type	Rotary		
Rotor Drive Type/Rotor Diameter	CVT Drive/30 in. (762 mm)		
Rotor Speeds	220–1180 rpm		
Number of Concave/Modules	2 pair		
Threshing/Separating Area Wrap	180°/180°		
Separating Grates/Modules	2 pair		
Discharge Beater Standard/Optional	Integral chopper/beater and chopper options available		
Auger Bed	No		
Active Grain Pan	Yes		
Grain Loss Monitor	Standard equipment		
Cage Vanes Standard/Optional	Manual adjust with turn buckle / In-cab adjustable		
CLEANING SYSTEM			
Cleaning System Width	1 575 mm		
Total Sieve Area	6.5 m ²		
Fixed or Self-Levelling Cleaning System	Self-levelling		
Cleaning Angle Capability	up to 12 degrees		
Sieve Louver Adjustment (In-Cab/Manual)	Standard/N/A		
Cleaning Fan Type/Drive	CrossFlow/hydraulic		
Fan Speed Range	300–1150 rpm		
Fan Diameter	391 mm		
CONVEYING AND STORAGE			
Tailings Elevator	Tri sweep crop processor		
Clean Grain Elevator (Dimensions/Capacity)	302×264 mm/6,500 bu/hr.		
Grain Tank Capacity Standard/Optional	11 100 L	14 400 L	
Unloading Auger Length	34 ft. (10.4 m)		
Unloading Rate	4.0 bu. (141 L) per second	4.5 bu. (159 L) per second	
DIMENSIONS			
Wheel Base - 2WD Axle / Pra Opt.	147.7 in. (3 752 mm)/148.5 in. (3 772 mm) - PGA		
Width (Overall Single Tires 120-in. Tread)	3 861 mm	3 962 mm	
Minimum Weight (2WD and Single Drive Tires)	19 162 kg	19 434 kg	19 863 kg
Typical Weight (2WD and Dual Drive Tires)	21 037 kg	21 309 kg	21 738 kg
Cab Height	3 899 mm	3 904 mm	



CASE IH

AXIAL-FLOW

SAFETY NEVER HURTS!™ Always read the Operators Manual before operating any equipment. Inspect equipment before using it, and be sure it is operating properly. Follow the product safety signs, and use any safety features provided. CNH Industrial Australia Pty Ltd reserves the right to make improvements in design and changes in specifications at any time without notice and without incurring any obligation to install them on units previously sold. Specifications, descriptions and illustrative material herein are as accurate as known at time of publication, but are subject to change without notice. Availability of some models and equipment builds varies according to the country in which the equipment is used.

©2018 CNH Industrial Australia Pty Ltd. All rights reserved. Case IH, its respective logos and the red, black and grey colour scheme, as well as corporate and product identity used herein, are trademarks of CNH Industrial N.V. And may not be used without permission. Case IH is a trademark registered in the United States and many other countries, owned by or licensed to CNH Industrial N.V., its subsidiaries or affiliates. Printed in Australia. www.caseih.com

19AUS50AF001

CASE IH
AGRICULTURE