

PANORAMIC P60.10

- ▶ **Kubota Tier III Engine, 100Horsepower**
- ▶ Proven **Merlo winning performance** in a larger, more adept machine
- ▶ **Boom side shift and frame levelling** as standard
- ▶ **Ring of steel** for additional **stability and protection**



SINCE 1964

Merlo's larger and heavier range to match customers different needs



PANORAMIC P60.10

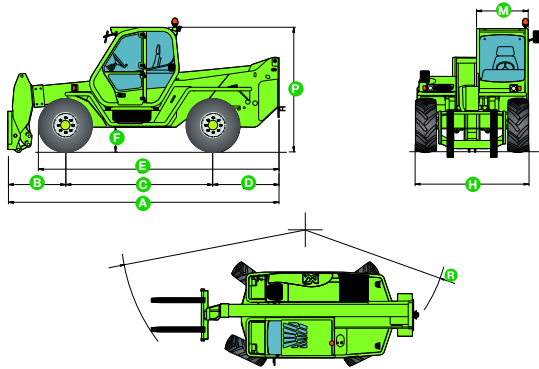

DIMENSIONS

A (mm)	5,345
B (mm)	1,235
C (mm)	2,875
D (mm)	1,300
E (mm)	4,645
F (mm)	480
H (mm)	2,330
M (mm)	995
P (mm)	2,440
R (mm)	3,950

PERFORMANCE

Unladen Weight (kg)	9,800
Maximum Load Capacity (kg)	6,000
Maximum Lift Height (m)	9.55
Capacity at Maximum Height (kg)	2,000
Maximum Reach (m)	5.3
Capacity at Maximum Reach (kg)	1,200
Boom Side-Shift (mm)	±250
Frame Levelling (%)	±10

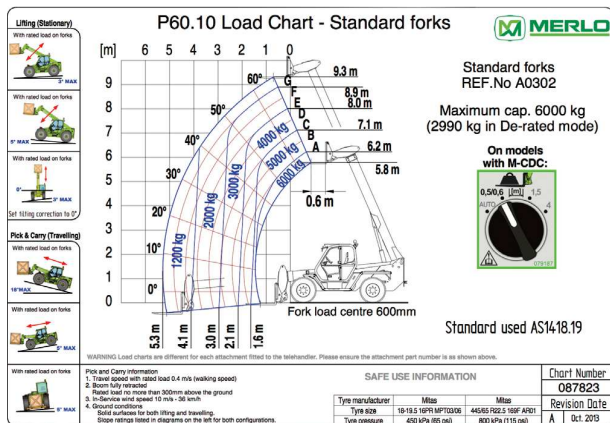

STANDARD SPECIFICATIONS

Engine	
Turbo Engine	Kubota V3800 Euro III
Range/Cylinders	3800/4
Engine Power (kW/HP)	74/100
Maximum Speed (km/h)	40
Fuel Tank Capacity (l)	140

Transmission	
Hydrostatic Merlo Transmission	Std
Speeds	2
Dual Reverse Shuttle System	Std
Pedal Inching-Control	Std
Permanent Four-Wheel Drive	Std

Brakes	
Automatic Parking Brake	Std
External Dry Disc Service Brakes	Std

Tyres	
Standard Tyres	445/65 R22.5

Cab	
Air Conditioned Cabin	Std
Air Suspension Seat	Std
FOPS (ISO 3449) and ROPS (ISO 3471) Cab	Std

Steering	
All Wheel Steering	Std

Instruments	
Electromechanical Joystick Control	Std
Merlo Dynamic Load Control (M-CDC)	Std
Reversing Camera	Std

Hydraulic System-Implement	
Load-Sensing Hydraulic System (bar-l/min)	210/115
Hydraulic Oil Tank Capacity (l)	105
Auxiliary Hydraulic Service on Boom	Std

Accessories and Attachments	
Tac-Lock Attachment Locking	Std
Standard Forks	Std
Fork Extensions	Optional
Digging Bucket	Optional
Re-Handling Bucket	Optional
4 x 1 Bucket	Optional
Crane Hook	Optional
Reduced Height Crane Jib	Optional
Fork Rotator	Optional

EXTRA SPECIFICATIONS

Boom Side Shift	Std
Frame Levelling	Std



120-124 Toongabbie Road Girraween 2145 NSW Australia
For further information please call **1300 657 325** or visit merloaustralia.com.au

Merlo reserves the right to modify and update the contents of this document at any time. Information and technical data are as available at time of printing.

For current information on Merlo products please contact your Merlo dealer.

ABN 87116110751 **MER-P60.10-2018**