



PANORAMIC HM P120.10HM EE



MERLO

PERFORMANCE AND FEATURES	P120.10HM EE		
PERFORMANCE			
Total unladen weight (kg)	16200		
Maximum capacity (kg)	10000		
Lifting height (m)	9,8		
Maximum reach (m)	5,4		
Maximum operating height (m)	6,6		
Maximum operating reach (m)	1,4		
Capacity at maximum height (kg)	4000		
Capacity at maximum reach (kg)	2300		
Lateral boom movement (mm)	± 185		
Tilting correction (%)	± 8		
Boom sections	2		
POWERTRAIN			
Turbo motor	FPT NEF45		
Displacement/cylinders	4500/4		
Engine Power (kW/HP)	125/170		
Anti-pollution technology	TIER 2, STAGE II		
Reversible fan	-		
Maximum speed (km/h)	40		
Fuel tank (l)	150		
AdBlue tank (l)	-		
Hydrostatic transmission	CVTronic		
EPD	Top		
Axles	Axial		
Reduction hub	Epicyclic		
Machine brakes	Wet disc		
Automatic parking brake	●		
HYDRAULIC			
Hydraulic pump	LS + FS		
Flow rate/pressure (l/min – bar)	119 - 210		
Hydraulic tank	149		
Hydraulic outlet at the top of the boom	●		
Rear hydraulic outlets	○		
CAB			
Cab configuration	Premium		
MCDC	Complet		
FOPS LIV II cab	●		
ROPS cab	●		
Cab commands	Electronic joystick		
Tilting Cab	-		
Reverse shuttle	Dual reverse		
CONFIGURATION			
Cab suspension	-		
Boom suspension	-		
Suspension on axles	○		
Work headlights on cab	●		
Sun blind	●		
Tac-lock	●		
Provision for a platform	○		
Two floating forks	●		
Inching-Control	●		
Four-wheel drive	●		
Four-wheel steering	●		
Three steering modes	●		
Standard tyres	17.5-25"		
Optional tyres	-		
Stabilisers	-		
Turret rotation	-		
Type approval as an agricultural tractor	-		
Approval with PNEUMATIC braking	-		
Approval with HYDRAULIC braking	-		
PTO	-		
3-point linkage	-		

- Not Available. ● standard. ○ optional.

LOAD CHARTS

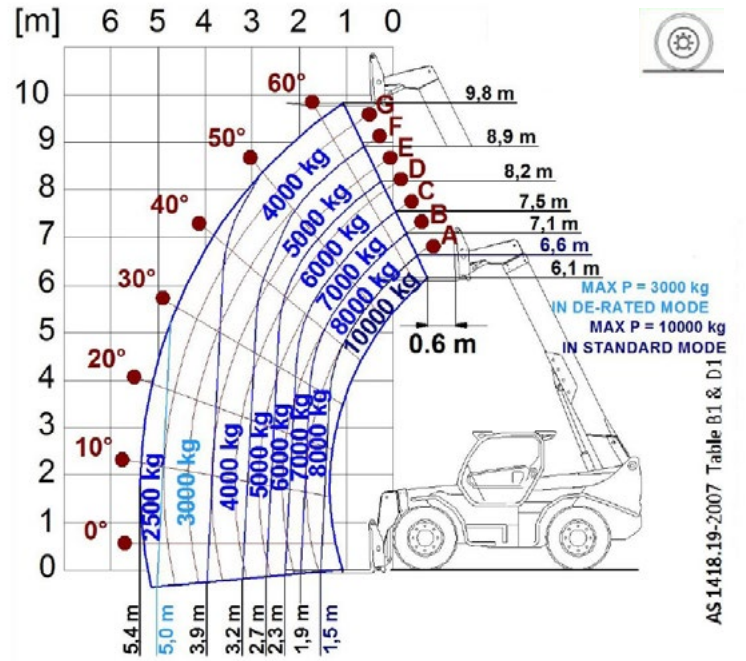

P120.10HM EE

DIMENSIONS

	P120.10 HM EE		
A (mm)	5720		
B (mm)	1145		
C (mm)	3240		
D (mm)	1335		
E (mm)	5210		
F (mm)	450		
H (mm)	2520		
M (mm)	1010		
P (mm)	2850		
R (mm)	4300		
S (mm)	5700		
Z (mm)	635/1170		

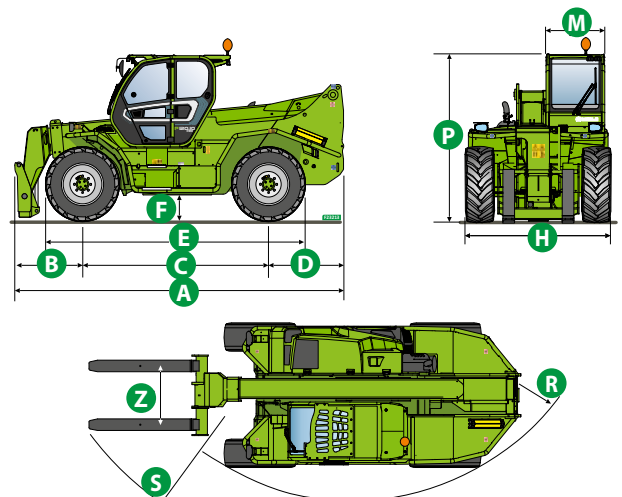



MERLO GROUP AUSTRALIA PTY LTD

27 Colin Jamieson Dve, Welshpool (Perth), WA 6106
Tel. (08) 9358 3110 - Fax (08) 9358 4110

120 Toongabbie Road, Girraween, NSW 2145
Tel. (02) 9688 0600

Tel:1300 657 325

info@merloaustralia.com.au
www.merloaustralia.com.au

Your Merlo dealer

DS_P120_0720_AUS