



TURBOFARMER MEDIUM DUTY
TF35.7-100 EE
TF33.9-100 EE



MERLO

PERFORMANCE AND FEATURES	TF35.7-100 EE	TF33.9-100 EE	
PERFORMANCE			
Total unladen weight (kg)	6600	6900	
Maximum capacity (kg)	3500	3300	
Lifting height (m)	6,6	8,6	
Maximum reach (m)	3,6	5,8	
Maximum operating height (m)	6,1	6,1	
Maximum operating reach (m)	1,3	1,5	
Capacity at maximum height (kg)	3000	1750	
Capacity at maximum reach (kg)	1250	550	
Lateral boom movement (mm)	-	-	
Tilting correction (%)	-	-	
Boom sections	2	3	
POWERTRAIN			
Turbo motor	Kubota V3800	Kubota V3800	
Displacement/cylinders	3800/4	3800/4	
Engine Power (kW/HP)	74/100	74/100	
Anti-pollution technology	TIER 3, STAGE IIIA	TIER 3, STAGE IIIA	
Reversible fan	●	●	
Maximum speed (km/h)	40	40	
Fuel tank (l)	80	80	
AdBlue tank (l)	-	-	
Hydrostatic transmission	● - 2V	● - 2V	
EPD	-	-	
Axles	Axial	Axial	
Reduction hub	Epicyclic	Epicyclic	
Machine brakes	Dry discs	Dry discs	
Automatic parking brake	●	●	
HYDRAULIC			
Hydraulic pump	LS+FS	LS+FS	
Flow rate/pressure (l/min – bar)	140-210	140-210	
Hydraulic tank	85	85	
Hydraulic outlet at the top of the boom	●	●	
Rear hydraulic outlets	○	○	
CAB			
Cab configuration	ECO	ECO	
MCDC	Complet	Complet	
FOPS LIV II cab	●	●	
ROPS cab	●	●	
Cab commands	Electronic joystick	Electronic joystick	
Tilting Cab	-	-	
Reverse shuttle	Dual reverse	Dual reverse	
CONFIGURATION			
Cab suspension	-	-	
Boom suspension	●	●	
Suspension on axles	-	-	
Work headlights on cab	●	●	
Sun blind	●	●	
Tac-lock	●	●	
Provision for a platform	○	○	
Two floating forks	●	●	
Inching-Control	●	●	
Four-wheel drive	●	●	
Four-wheel steering	●	●	
Three steering modes	●	●	
Standard tyres	405/70-24	405/70-24"	
Optional tyres	-	-	
Stabilisers	-	-	
Turret rotation	-	-	
Type approval as an agricultural tractor	-	-	
Approval with PNEUMATIC braking	-	-	
Approval with HYDRAULIC braking	-	-	
PTO	-	-	
3-point linkage	-	-	

- Not Available. ● standard. ○ optional.

LOAD CHARTS

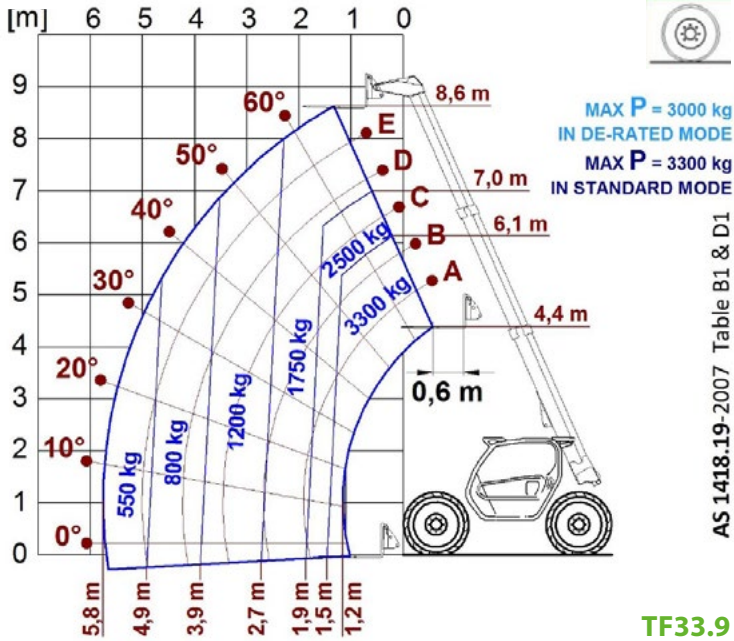

TF33.9

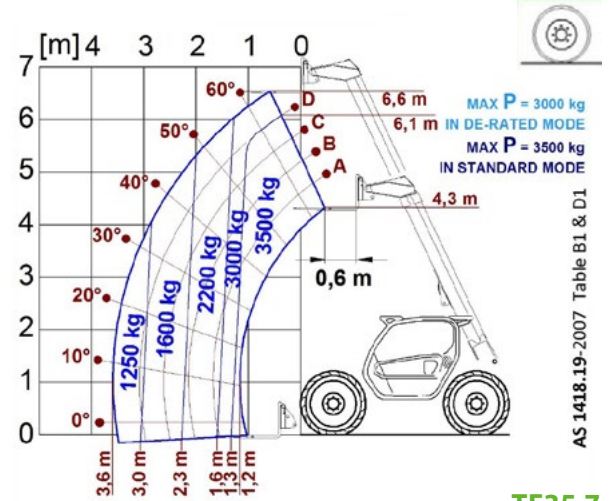

TF35.7

DIMENSIONS

	TF35.7 100 EE	TF33.9 100 EE	
A (mm)	4310	4330	
B (mm)	970	990	
C (mm)	2740	2740	
D (mm)	600	600	
E (mm)	3910	3910	
F (mm)	380	380	
H (mm)	2250	2250	
M (mm)	995	995	
P (mm)	2240	2240	
R (mm)	4095	4095	
S (mm)	4740	4740	
Z (mm)	850	850	

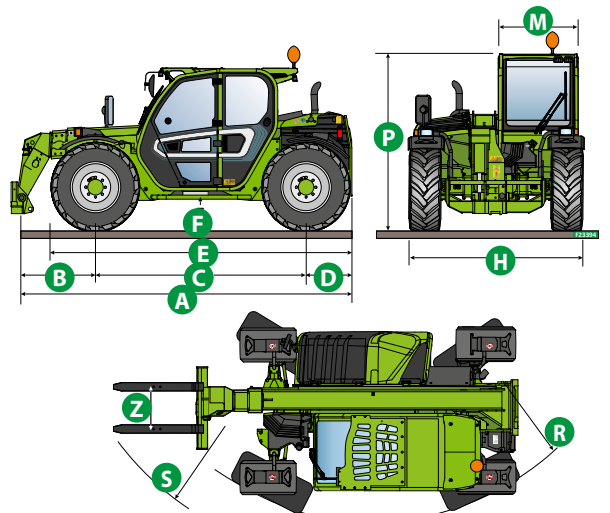



MERLO GROUP AUSTRALIA PTY LTD

27 Colin Jamieson Dve, Welshpool (Perth), WA 6106
Tel. (08) 9358 3110 - Fax (08) 9358 4110

120 Toongabbie Road, Girraween, NSW 2145
Tel. (02) 9688 0600

Tel:1300 657 325

info@merloaustralia.com.au
www.merloaustralia.com.au

Your Merlo dealer

DS_TF35.7100EE-TF33.9100EE_0720_AUS