

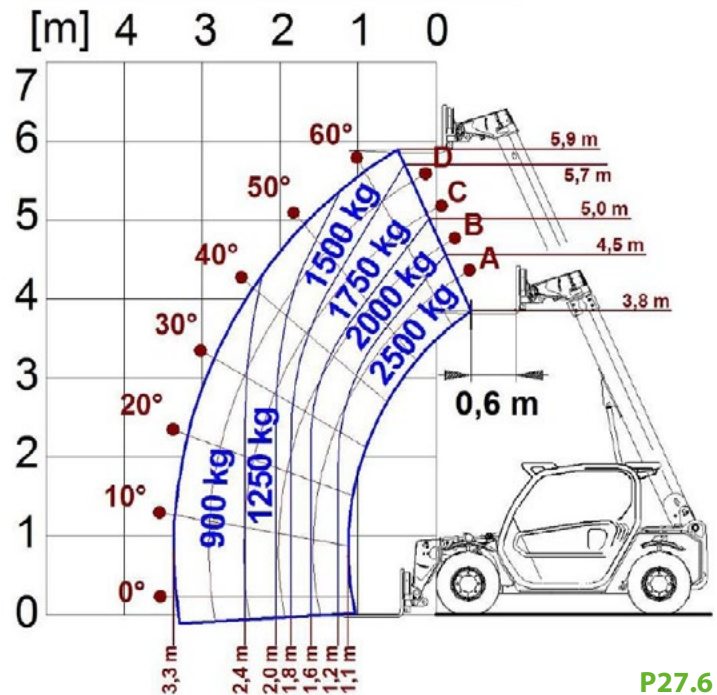

PANORAMIC P27.6



| PERFORMANCE AND FEATURES | P27.6AU | | |
|--|----------------------------|--|--|
| PERFORMANCE | | | |
| Total unladen weight (kg) | 4850 | | |
| Maximum capacity (kg) | 2500 | | |
| Lifting height (m) | 5,9 | | |
| Maximum reach (m) | 3,3 | | |
| Maximum operating height (m) | 4,5 | | |
| Maximum operating reach (m) | 1,2 | | |
| Capacity at maximum height (kg) | 1500 | | |
| Capacity at maximum reach (kg) | 900 | | |
| Lateral boom movement (mm) | - | | |
| Tilting correction (%) | - | | |
| Boom sections | 2 | | |
| POWERTRAIN | | | |
| Turbo motor | Kubota V3307 | | |
| Displacement/cylinders | 3300/4 | | |
| Engine Power (kW/HP) | 55,4/75 | | |
| Anti-pollution technology | EURO III | | |
| Reversible fan | - | | |
| Maximum speed (km/h) | 40 | | |
| Fuel tank (l) | 70 | | |
| AdBlue tank (l) | - | | |
| Hydrostatic transmission | ● - 1V | | |
| EPD | - | | |
| Axles | Axial | | |
| Reduction hub | Epicyclic | | |
| Machine brakes | Dry discs | | |
| Automatic parking brake | ● | | |
| HYDRAULIC | | | |
| Hydraulic pump | Gear | | |
| Flow rate/pressure (l/min – bar) | 94-210 | | |
| Hydraulic tank | 70 | | |
| Hydraulic outlet at the top of the boom | ● | | |
| Rear hydraulic outlets | ○ | | |
| CAB | | | |
| Cab configuration | ECO | | |
| MCDC | ● | | |
| FOPS LIV II cab | ● | | |
| ROPS cab | ● | | |
| Cab commands | Electromechanical joystick | | |
| Tilting Cab | - | | |
| Reverse shuttle | Finger touch | | |
| CONFIGURATION | | | |
| Cab suspension | - | | |
| Boom suspension | ○ | | |
| Suspension on axles | - | | |
| Work headlights on cab | ○ | | |
| Sun blind | ○ | | |
| Tac-lock | ● | | |
| Provision for a platform | ○ | | |
| Two floating forks | ● | | |
| Inching-Control | ● | | |
| Four-wheel drive | ● | | |
| Four-wheel steering | ● | | |
| Three steering modes | ● | | |
| Standard tyres | 12,0/75-18" | | |
| Optional tyres | - | | |
| Stabilisers | - | | |
| Turret rotation | - | | |
| Type approval as an agricultural tractor | - | | |
| Approval with PNEUMATIC braking | - | | |
| Approval with HYDRAULIC braking | - | | |
| PTO | - | | |
| 3-point linkage | - | | |
| DIMENSION | | | |
| Width (mm) | 1840 | | |
| Height (mm) | 2000 | | |
| Length (mm) | 3910 | | |
| Wheelbase (mm) | 2450 | | |



P27.6

GLOSSAR

SCR

Selective Catalyst Reduction, solution used for the reduction of NOx in the exhaust gases through the injection of a liquid - UREA (AdBlue) - into the exhaust gases.

DPF

Diesel Particulate Filter, a solution used to reduce fine particle emissions in exhaust gases

DOC

Diesel Oxidation Catalyst, a solution used to reduce carbon monoxide (CO) and hydrocarbons in exhaust gases

EGR

Exhaust Gas Recirculation, a solution used to reduce NOx in exhaust gases by recirculating gas inside the combustion chamber of the engine.

1-2V

1 or 2 speed **Merlo gearbox**

CVTronic

Continuous variation Merlo gearbox, for constant acceleration without loss of torque

EPD

Eco Power Drive, Merlo electronically-controlled hydrostatic transmission Electronic, enables effective RPM management in order to reduce overall fuel consumption by the machine

EPD Plus

In addition to the **EPD** Control, it is also possible to work using Speed Control (maintaining a constant travel speed) and Heavy Load (management of RPM in order to maximise performance for tasks such as: bucketing operations, heavy duty unloading, etc.)

EPD Top

In addition to the **EPD Plus** control function, this enables the RPM to be managed directly using the joystick

Gear

Fixed displacement pump with gears, combined with an open centre hydraulic distributor

LS

Variable displacement pump with **Load Sensing** control, combined with a closed centre hydraulic distributor

LS+FS

Variable displacement pump with **Load Sensing** control, combined with a closed centre hydraulic distributor equipped with solenoid valves and **Flow Sharing** control.

Kabine ECO/PREMIUM

MODULAR type cabin with simplified or PREMIUM equipment

MCDC

Merlo Dynamic Load Control, electronic control of the machine's anti-overflow system.

• **Light**: Simplified version; • **Complete**: Version with display in cab.

FOPS

Falling object protective structure, the system which shields the operator from heavy objects falling onto the cab. Two levels:
• **FOPS Liv I**: Object with a weight of 45 kg falling from 3 metres • **FOPS Liv II**: Object with a weight of 227 kg falling from 5.2 metres

ROPS

Roll-over protection system (or roll-over protection structure), the system that protects the operator if the vehicle rolls over

Finger Touch

Driving direction inversion system mounted on the steering column

Dual Reverse

Dual driving direction inversion system, on both the steering column and the joystick

Tac-lock

Hydraulic attachment clamping system controlled from the cab



MERLO S.P.A.

Via Nazionale, 9
12010 S. Defendente di Cervasca
(Cuneo) Italia

Tel. +39 0171 614111

Fax +39 0171 684101

info@merlo.com

www.merlo.com

